

UDC: 634.1-13.

## SUBSTANTIATION OF THE PARAMETERS OF THE DEEP LOOSENER-FURROW OPENER IMPLEMENT FOR A TREE SEEDLING PLANTING MACHINE

<https://doi.org/10.5281/zenodo.20096333>

**Ergashev M.M**

*Doctor of Technical Sciences, PhD, Senior Researcher,*

**Mukimov Z.A**

*Doctoral student, Scientific-Research Institute of Agricultural Mechanization*

### Abstract

The article presents the results of theoretical studies on substantiating the parameters of the chisel (working body) of a deep loosener-furrow opener developed for a machine that performs continuous planting of fruit tree seedlings. Based on the obtained results, it was determined that, in order to prevent the formation of a compacted furrow with dense walls at the bottom of the cultivated soil layer and to ensure soil deformation and fragmentation processes at the required level, the width of the shank of the deep loosener-furrow opener should be at least 10 cm, and its length should be in the range of 9,3-8,8 cm.

### Keywords

tree planting machine, chisel, chisel width and length, processing depth, wall-mounted compacted furrow, soil deformation, soil compression, soil crumbling quality, movement speed, traction resistance.

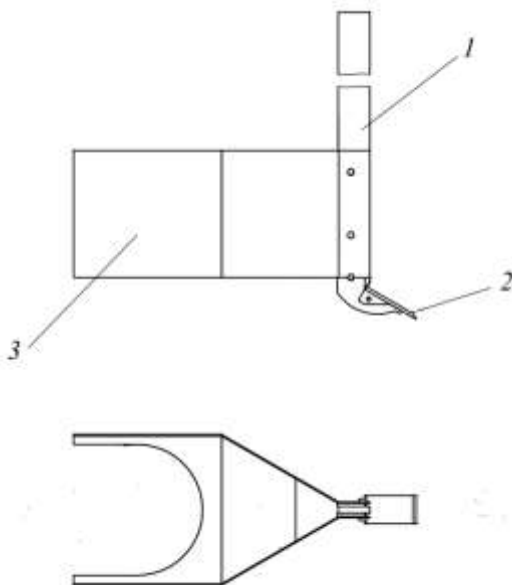

**Figure 1. Structural diagram of the deep ripper-cutter**

**Introduction.** Currently, in our republic, before planting seedlings, the soil is plowed to a depth of 30-35 cm, chiselled, and subsequently harrowed. After these processes are fully completed, pits for planting seedlings are dug in the designated area. Pits are excavated using special KYA-100, KNYU-100, and KRK-60 excavators or manually at a size of 60x60x60 cm. The planting of seedlings is

performed entirely by hand. This leads to high labor costs and other expenses. Based on the above, a machine for the continuous planting of fruit tree seedlings (hereinafter referred to as the tree seedling planting machine) has been developed at the Scientific-Research Institute of Agricultural Mechanization for use in the creation of new orchards, and scientific research is being conducted to substantiate its parameters.

The machine for planting tree seedlings consists of a frame, a hanging device, a furrower-softener, a disc digger, a compactor with a conical roller, a place for the seedling reserve (bunker), a seat, a press, and screens [1]. In addition, careful consideration was given to the seedling structure and the agrotechnical requirements of planting when selecting the parameters of the planting machine [2, 3].

**Research materials and methods.** Box-shaped, anchor-shaped, wedge-shaped, asymmetric, combined, and additional element chisels are used as the working elements for cutting and loosening the soil layer of existing tree seedling planting machines [4, 5]. However, they are primarily designed for machines used for planting forest, ornamental, and shrubby tree seedlings. The root system of fruit tree seedlings differs from the root systems of forest, ornamental, and shrub tree seedlings, and the agrotechnical requirements for their planting are different. Therefore, the optimal placement of the root system of fruit tree seedlings at a specific depth and width is required.

Based on the aforementioned, we have developed a deep-sowing furrow cutter for a machine for planting fruit tree seedlings, which consists of a post 1, a chisel 2 installed on it, and a housing (furrow cutter) 3 (Fig. 1).

The developed furrow ripper is the main working element of fruit tree seedling planting machines; during operation, its deep ripper chisel penetrates the soil and forms a vertical narrow fissure; as a result of the wedge-shaped front part of the furrow ripper pushing the soil to the sides and lifting it upward, the narrow fissure expands, forming mounds of soil along the side walls - that is, hummocks - forming a sowing furrow.

This article presents the results of research conducted to substantiate the parameters of the deep ripper-cutter chisel for tree seedling planting machines, which were conducted using the rules and laws of theoretical mechanics and agricultural mechanics.

**Results and their analysis.** To solve the problem, we first find the width of the furrow-softener chisel. We determine the width of the subsoiler chisel using the following expression, derived from the condition that it does not form a groove with compacted walls at the bottom of the layer being processed [6].

$$b_i \geq \frac{(m + ctg \beta)h}{\left[0,1 \frac{T_e}{k_s} (1 + 3tg \varepsilon) - k\right]}, \quad (1)$$

here  $m$  and  $k$  – coefficients without units of measurement related to the physical and mechanical properties of the soil;  $h$  – depth of the chisel's penetration into the soil, m;  $T_e$  – specific compressive strength of soil, Pa;  $\varepsilon$  – the angle of inclination of the resultant of the soil resistance forces acting on the chisel from the horizontal, °;  $k_s$  – shear resistance of soil, Pa.

It is known from the literature [7]:

$$\varepsilon = 90^\circ(\beta + \varphi_1), \quad (2)$$

Taking this into account, (1) takes the following form:

$$b_i \geq \frac{(m + ctg \beta)h}{\left[0,1 \frac{T_e}{k_s} (1 + 3tg(\beta + \varphi_1)) - k\right]}. \quad (3)$$

$m = 4,2$ ;  $k = 2,5$ ;  $\beta = 30^\circ$ ;  $h = 0,38$  m;  $T_e = 10,2 \cdot 10^5$  Pa;  $k_s = 2 \cdot 10^4$ ;  $\varphi_1 = 30^\circ$  according to the accepted calculations, the chisel width must be at least 10 cm.

To determine the length of the excavator chisel, let us consider the processes of soil deformation and fragmentation under the action of the chisel [6-9]. When the chisel moves from position 1 to position 2 (Fig. 2), the soil is primarily compressed (compressed) under its action, and when the stresses generated in it reach a critical value, it decomposes in the  $ABB_1A$  plane, which is located at an angle of  $\psi = \frac{\pi}{2} - \frac{1}{2}(\beta + \varphi_1 + \varphi_2)$  to the direction of motion, and a lump in the form of a prism  $ABB_1A_1DCC_1D_1$  is separated from it.

According to the scheme shown in Figure 2, when the chisel moves from position 1 to position 2, the following condition must be met for the soil to break down, i.e., to be loosened.

$$l_i > AD. \quad (4)$$

In this expression, we express  $AD$  as the distance  $S$  traveled by the chisel from the moment the soil is compressed until crumbling.

Applying the law of sines from the diagram in Figure 2, we obtain the following:

$$AD = \frac{S \sin \psi}{\sin(\beta + \psi)}. \quad (5)$$

Taking this into account, expression (4) takes the following form:

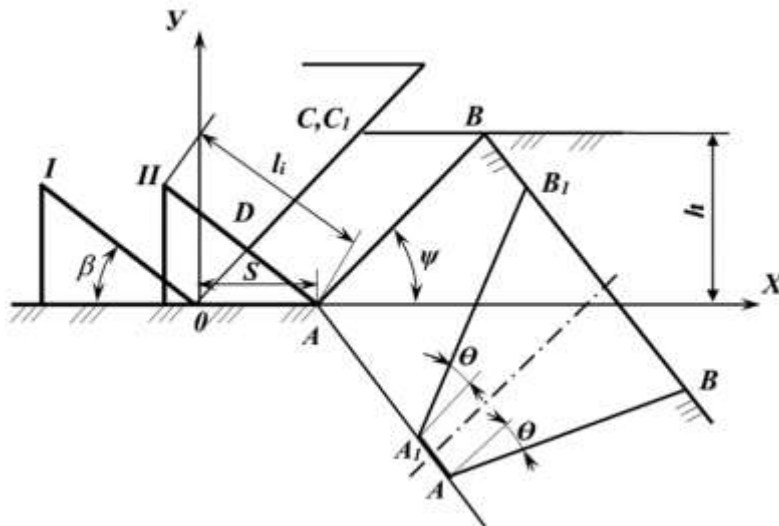

**Figure 2. Deformation and fragmentation of soil under the influence of a deep-soil loosening and furrow-cutting chisel**

$$l_i > \frac{S \sin \psi}{\sin(\beta + \psi)}. \quad (6)$$

Substituting the above value of into this expression, we obtain the following result.

$$l_i > \frac{S \cos \frac{1}{2}(\beta + \varphi_1 + \varphi_2)}{\cos \frac{1}{2}(\varphi_1 + \varphi_2 - \beta)}. \quad (7)$$

Usually, chisels are made two-sided; that is, if one side is worn out, the other side is used. Taking this into account, expression (7) takes the following final form:

$$l_i > \frac{2S \cos \frac{1}{2}(\beta + \varphi_1 + \varphi_2)}{\cos \frac{1}{2}(\varphi_1 + \varphi_2 - \beta)}. \quad (8)$$

Let us now determine  $S$  in this expression, i.e., the distance traveled by the chisel from the moment the soil is compressed to the moment it crumbles. To do this, we analyze the forces exerted on the soil by the chisel.

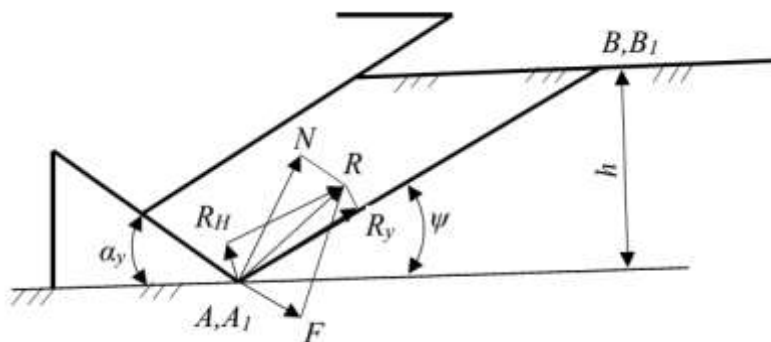

**Figure 3. Forces acting on the soil from the excavator chisel**

As shown in Figure 3, normal  $N$  and friction forces  $F = fN$  (where  $f$  is the coefficient of soil friction against the working surface of the chisel) act on the soil from the chisel side, and according to Coulomb-Mor theory [10]:

$$N = \frac{k_s \left[ b_i + htg\left(\frac{\pi}{4} - \frac{\varphi_2}{2}\right) \right] h \cos \varphi_1 \cos \varphi_2}{\cos^2 \frac{1}{2}(\beta + \varphi_1 + \varphi_2)}. \quad (9)$$

We express the normal force acting on the soil from the chisel through its resistance to crushing, i.e., the soil's resistance to crushing [11].

$$N = q_0 F_{ADO} b_i, \quad (10)$$

here  $q_0$  - coefficient of volumetric soil compression, N/m<sup>3</sup>;  $F_{ADO}$  - the cross-section of the crushed soil when the chisel moves from position 1 to position 2, i.e., the area of the  $ADO$  triangle in Figure 2, m<sup>2</sup>.

Taking into account the speed of the chisel [12, 13]

$$N = q_0' (1 + k_v V^2) F_{ADO} b_i. \quad (11)$$

here  $q_0'$  - coefficient of static volumetric soil compression, N/m<sup>3</sup>;  $k_v$  - proportionality coefficient, c<sup>2</sup>/m<sup>2</sup>.

From Figure 2:

$$F_{ADO} = \frac{S^2 \sin \psi \sin \beta}{2 \sin(\beta + \psi)}, \quad (12)$$

or taking into account the above value of  $\psi$ :

$$F_{ADO} = \frac{S^2 \cos \frac{1}{2}(\beta + \varphi_1 + \varphi_2) \sin \beta}{2 \cos \frac{1}{2}(\varphi_1 + \varphi_2 - \beta)}. \quad (13)$$

Taking this into account, expression (11) takes the following form:

$$N = \frac{q_0' (1 + k_v V^2) b_i S^2 \cos \frac{1}{2}(\beta + \varphi_1 + \varphi_2) \sin \beta}{2 \cos \frac{1}{2}(\varphi_1 + \varphi_2 - \beta)}. \quad (14)$$

Let us equalize the right sides of expressions (9) and (14), i.e.,

$$\frac{k_s \left[ b_i + htg\left(\frac{\pi}{4} - \frac{\varphi_2}{2}\right) \right] h \cos \varphi_1 \cos \varphi_2}{\cos^2 \frac{1}{2}(\beta + \varphi_1 + \varphi_2)} = \frac{q_0' (1 + k_v V^2) b_i S^2 \cos \frac{1}{2}(\beta + \varphi_1 + \varphi_2) \sin \beta}{2 \cos \frac{1}{2}(\varphi_1 + \varphi_2 - \beta)}. \quad (15)$$

From this expression, we determine  $S$ :

$$S = \frac{\sqrt{2}}{\cos^2 \frac{1}{2}(\beta + \varphi_1 + \varphi_2)} \left\{ k_s \left[ b_i + htg\left(\frac{\pi}{4} - \frac{\varphi_2}{2}\right) \right] h \cos \varphi_1 \cos \varphi_2 \times \right. \\ \left. \times \cos \frac{1}{2}(\varphi_1 + \varphi_2 - \beta) \right\}^{\frac{1}{2}} : \\ : \left[ q_o'(1 + k_v V^2) b_i \cos \frac{1}{2}(\beta + \varphi_1 + \varphi_2) \sin \beta \right]^{\frac{1}{2}}. \quad (16)$$

From the analysis of this expression, it can be seen that the distance traveled by the chisel from soil compression to its fragmentation, and consequently the quality of soil crumbling and the traction resistance of the chisel, depend on the physical and mechanical properties of the soil ( $\varphi_1, \varphi_2, k_s, q_o', k_v$ ), the tillage depth ( $h$ ), the movement speed ( $V$ ), and the chisel's parameters.

The smaller the distance  $S$ , the higher the crumbling quality of the soil and the lower the traction resistance; the greater the distance  $S$ , the worse the crumbling quality of the soil and the higher the traction resistance.

Substituting the value of  $C$  according to (16) into (8), we obtain the following final result.

$$l_i > \frac{2\sqrt{2}}{\cos \frac{1}{2}(\varphi_1 + \varphi_2 - \beta)} \left\{ k_s \left[ b_i + htg\left(\frac{\pi}{4} - \frac{\varphi_2}{2}\right) \right] h \cos \varphi_1 \cos \varphi_2 \times \cos \frac{1}{2}(\varphi_1 + \varphi_2 - \beta) \right\}^{\frac{1}{2}} : \\ : \left[ q_o'(1 + k_v V^2) b_i \cos \frac{1}{2}(\beta + \varphi_1 + \varphi_2) \sin \beta \right]^{\frac{1}{2}}. \quad (17)$$

Assuming  $k_s=2 \cdot 10^4$  Pa,  $q_o'=1 \cdot 10^7$  N/m<sup>3</sup>,  $\varphi_1=30^\circ$  and  $\varphi_2=40^\circ$ , in Fig. 4, graphs of the change in  $l_i$  depending on  $b_i, h$ , and  $\beta$  are constructed. It can be seen that an increase in  $b_i$ , i.e., the width of the chisel's grip and the angle of entry into the soil, leads to a decrease in its length, while an increase in the depth of penetration into the soil leads to its increase.

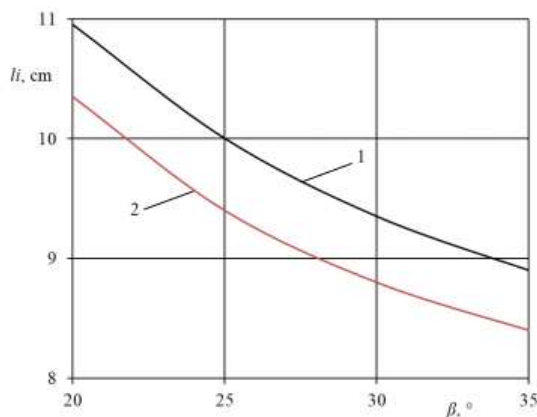

a)

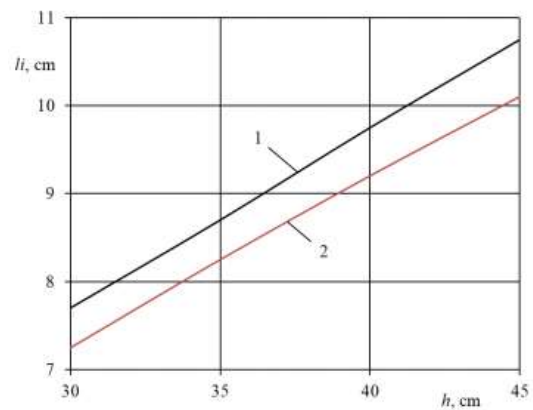

b)

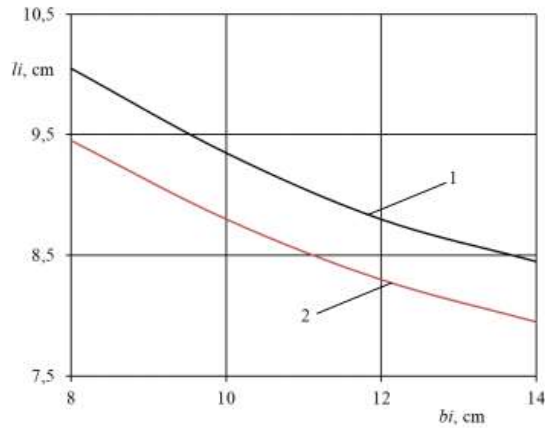

c)

**Figure 4. Graph of the change in  $l_i$  depending on  $b_i$  (a),  $h$  (b), and  $\beta$  (c).**

Substituting the aforementioned and determined values of  $\beta$ ,  $\varphi_1$ ,  $\varphi_2$ ,  $k_s$ ,  $b_i$ ,  $h$ ,  $q_0'$  into expression (7), we determine that according to expression (17), the length of the deep-softening furrow cutter chisel should be in the range of 9,3-8,8 cm at movement speeds of 0.8–1.4 m/s.

Conclusion. According to the results of the conducted research, the width of the deep-softening furrow cutter chisel must be at least 10 cm and its length 9,3-8,8 cm, ensuring that the soil crumbles at the required level and does not form a furrow with compacted walls at the bottom of the treated layer.

#### REFERENCES:

1. Ergashev M.M., Akbarov I.A., Abdubannopov A.A., Mukimov Z.A. Machine for continuous planting of fruit tree seedlings // Innovative solutions for creating highly efficient agricultural machinery and increasing the level of use of technical means: International Scientific and Technical Conference. - Тошкент, 2021. - P. 143-146.
2. Mukimov Z.A., Basing the processing depth and width of the machine's deep ripper-digger by analyzing the root system of fruit tree seedlings. Construction and education. Scientific journal, Special issue No. 2 2025. P. 49-52.
3. Mukimov Z.A., Why fruit tree seedlings should be planted by machine, Scientific news of FarDU, No. 3 2025. pp. 254-257.
4. Анисимов В.Н., Ковалев В.И. Лесные машины. - Москва: Лесная промышленность, 1988.
5. Бартнев И.М., Попиков П.И. Машины и механизмы в лесном хозяйстве. - Тошкент, 2020.

6. Tukhtakuziev A., Imomkulov K.B. Scientific and technical foundations of soil deformation and fragmentation with low energy consumption / Monograph. - Тошкент, 2017. - 120 p.
7. Синеоков Г.Н., Панов И.М. Теория и расчет почвообрабатывающих машин. - М.: Машиностроение, 1977. - 328 с
8. Кленин Н.И., Сакур В.А. Сельскохозяйственные и мелиоративные машины. - Москва: Колос, 1980. - 617 с.
9. Карпенко А. Н., Халанский В. М. Сельскохозяйственные машины. - Москва, 1989. - 527 с
10. Гнилomedов В.П. Разбрасывание почвы лапами пропашного культиватора с изменением скорости движения // Известие Куйбышевское сельскохозяйственного института. Том 15. - Куйбышев: Куйбышевское книжное издательство, 1969, -С.43-61.
11. Бурченко П.Н. К вопросу взаимодействия почвенного пласта и плоского клина //Труды института//ВИМ. - Москва, 1978. -Т. 82. -С.138-155.
12. Панов И.М.б Ветохин В.И. Физические основы механики почвю. - Киев: Феникс, 2008. -265 с.
13. Ширяев А.М. Припосевное уплотнение почвы //Механизация сельского хозяйства// - Москва, 1988. - №3. -С.33-35